

REVISION	DESCRIPTION	DATE	SIGN	QC
-	FIRST RELEASE	2023-04-28	BOP	BJM
A	TABLE CREW ROOM AND PC WORKING PLACE WHEELHOUSE	2023-05-12	BOP	
A	ADDED 10 SEATS AT SUN DECK	2023-05-15	BOP	NPSS
B	DRAWING UPDATED	2023-06-13	BOP	NPSS
C	DRAWING UPDATED	2023-06-19	BOP	NPSS
D	HVAC ROOM REDUCED TO 4.7m	2023-07-05	BOP	NPSS
E	ADDED ANCHOR AND CAPSTAN	2023-08-10	BOP	MMPE
F	SALON DECK RAISED 150mm TO 6450 AB.BL.	29-08-2023	BOP	NPSS

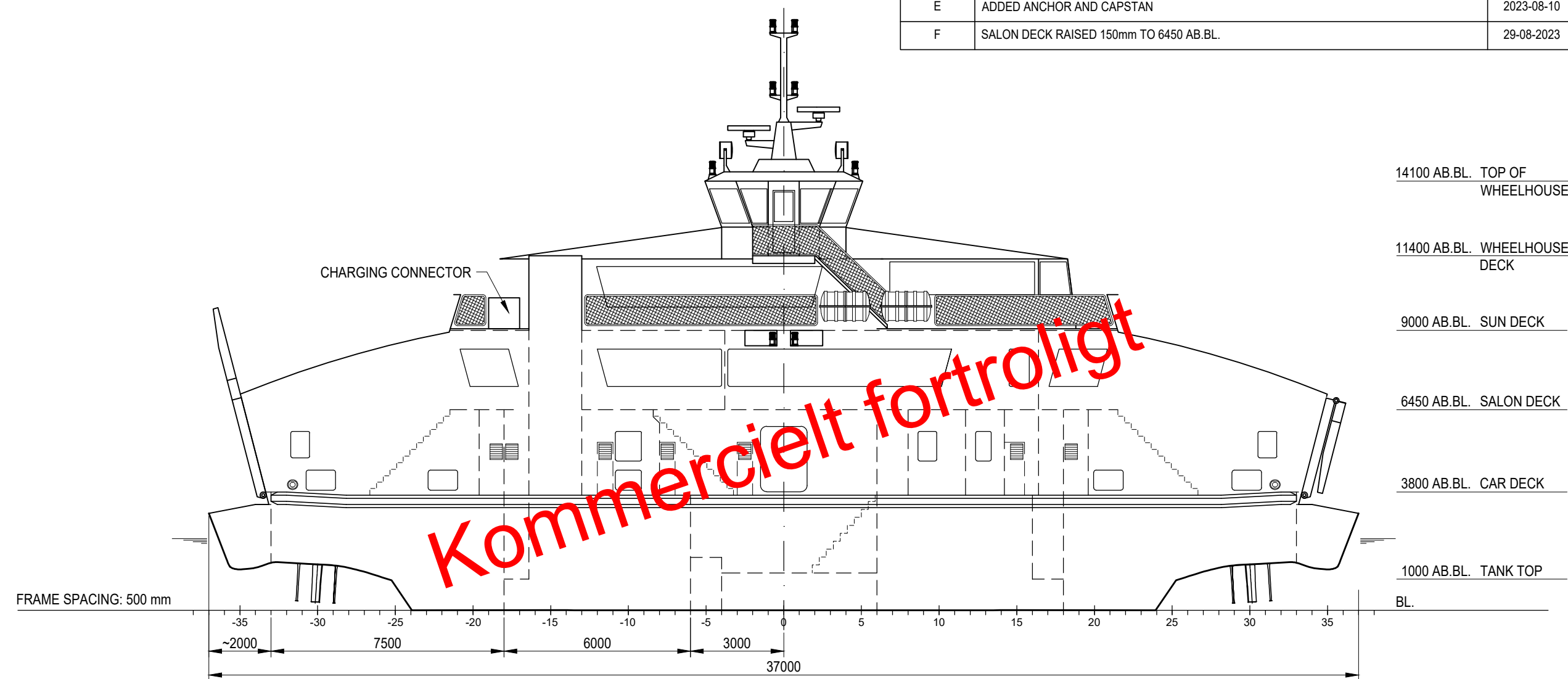

Kommercielt fortroligt

PROFILE

MAIN DIMENSIONS (ALL APPROX):

LENGTH OA MAX.	: 37.0 m
LENGTH PP APPROX. (LENGTH OF WATER LINE):	: -- m
BREADTH (MLD)	: 10.5 m
BREADTH FENDERS	: 10.9 m
DEPTH TO VEHICLE DECK (MLD)	: 3.8 m
SCANTLING DRAUGHT	: 2.3 m
SPEED	MAX.: 11.0 kn

CAPACITY:

PASSENGER MAX. (WINTER / SUMMER)	: 98 / 147 PERS.
SEATS (INSIDE / OUTSIDE)	: 78 / 75 PCS.
PASSENGER CARS (4.20 m x 1.75 m)	: 19 PCS.
TRUCKS LANE (22.00 m x 2.55 m)	: 1 PCS.
LANE METERS (CARS)	: 85 m
LANE METERS (TRUCKS/CARS)	: 22 m

PRELIMINARY

©2023. The information contained in this document is the property of Odense Maritime Technology A/S and shall be kept secret at all times. The information herein constitutes business secrets of Odense Maritime Technology A/S and is protected by copyright law and international copyright conventions. You may, however, print a number of copies for scrutiny by your employees and submit electronic copies to members of your project team. All copies, irrespective of format, of the information shall, upon Odense Maritime Technology A/S' request be returned or destroyed. Except as stated above, the information may not be shared with others, copied or reproduced in any way or format without the prior written consent of Odense Maritime Technology A/S.

OMT

Odense Maritime Technology A/S
www.odensemartime.com

Project: D37-10
STANDARD FERRY - SVENDBORG
GENERAL ARRANGEMENT
CONCEPT DESIGN

Project No.: M994	
Scale: 1:150	Size: A3
Drw.: BOP	Date: 2023-04-28
Drg. No.: 101-000-010	
Sheet 1 of 6	Rev.: F

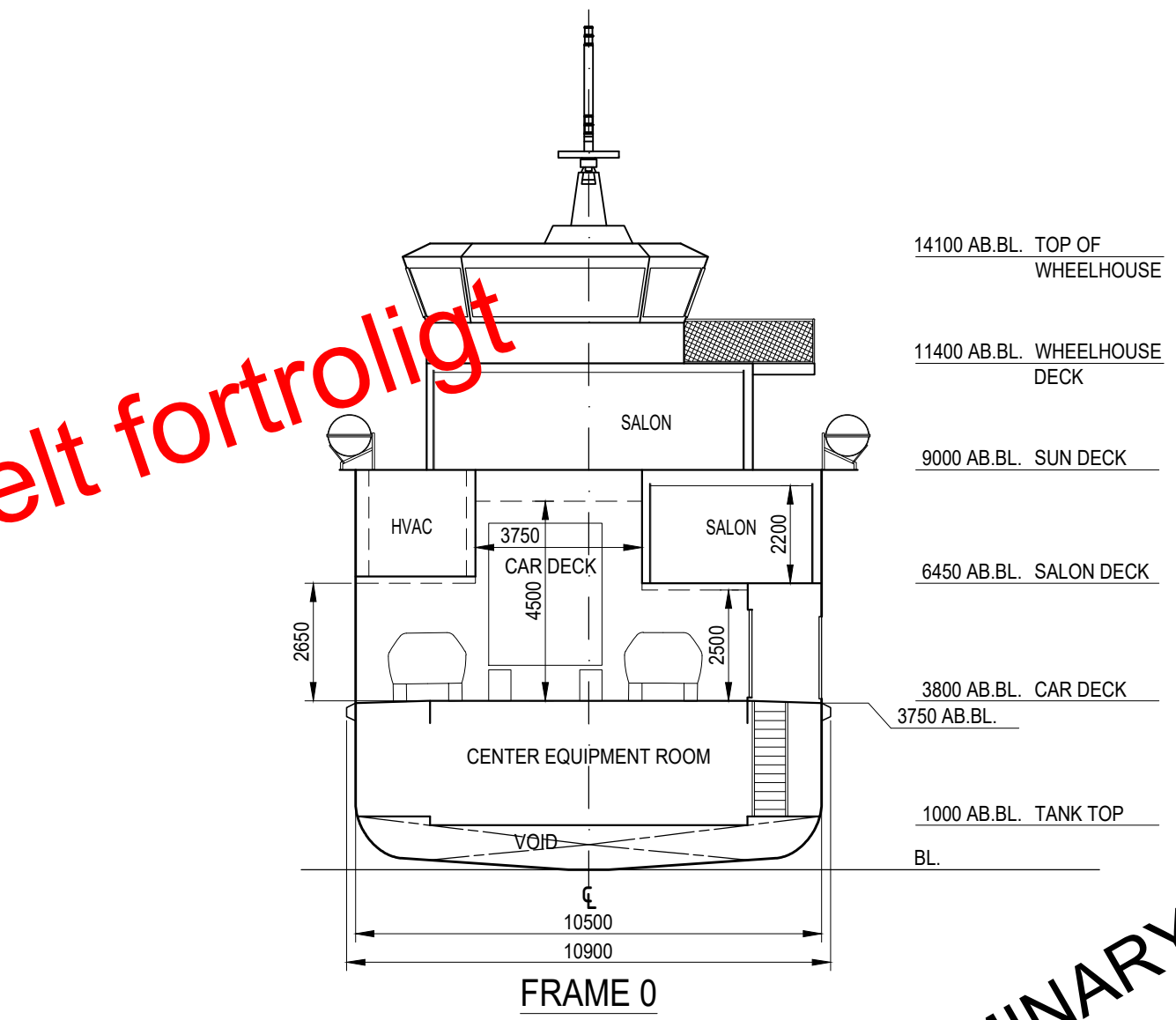
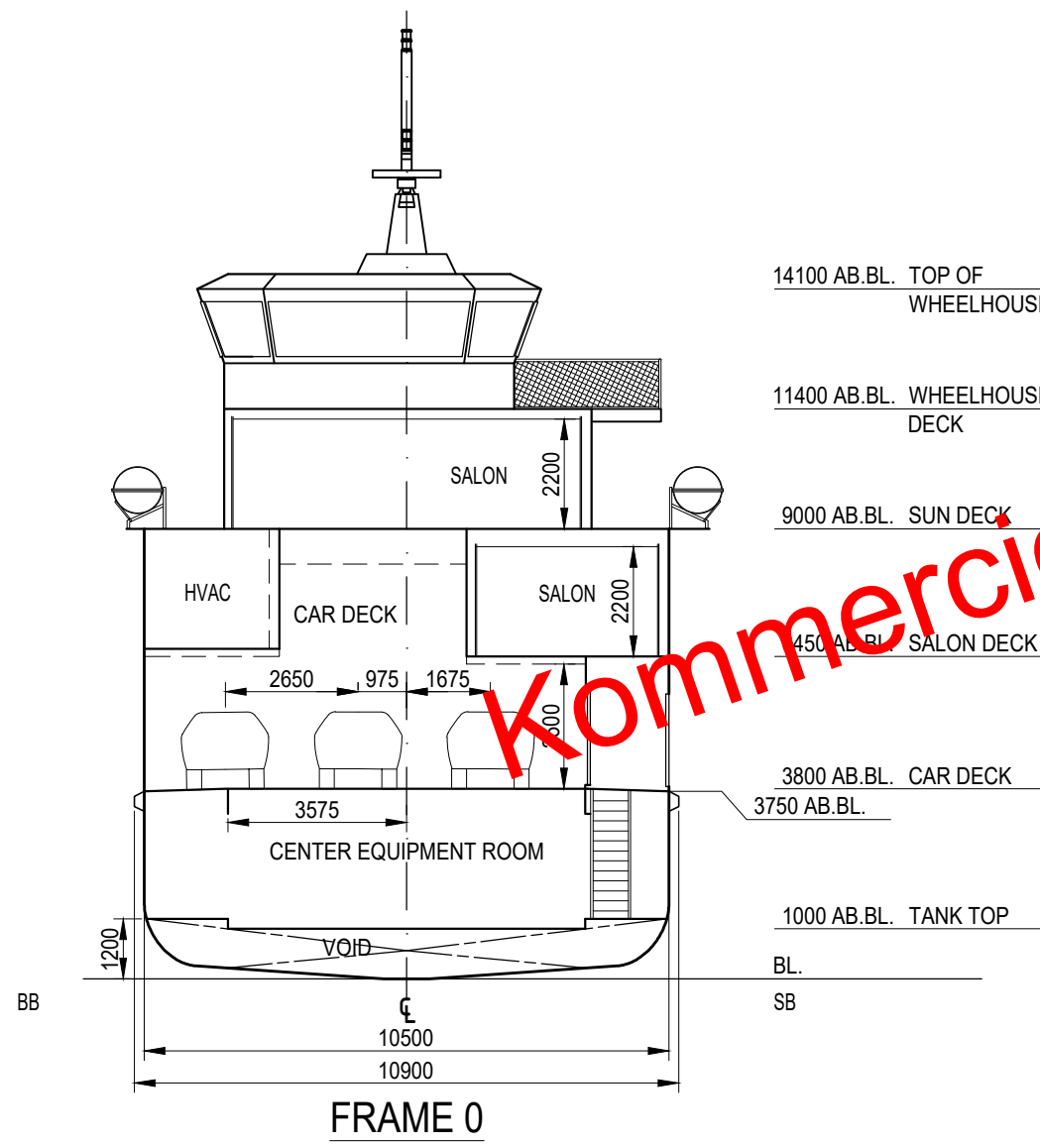

PRELIMINARY

©2023. The information contained in this document is the property of Odense Maritime Technology A/S and shall be kept secret at all times. The information herein constitutes business secrets of Odense Maritime Technology A/S and is protected by copyright law and international copyright conventions. You may, however, print a number of copies for scrutiny by your employees and submit electronic copies to members of your project team. All copies, irrespective of format, of the information shall, upon Odense Maritime Technology A/S' request be returned or destroyed. Except as stated above, the information may not be shared with others, copied or reproduced in any way or format without the prior written consent of Odense Maritime Technology A/S.



Project: D37-10
STANDARD FERRY - SVENDBORG
GENERAL ARRANGEMENT
CONCEPT DESIGN

Project No.: M994	
Scale: 1:150	Size: A3
Drw.: BOP	Date: 2023-04-28
Drg. No.: 101-000-010	
Sheet 2 of 6	Rev.: F

6 5 4 3 2 1

D

D

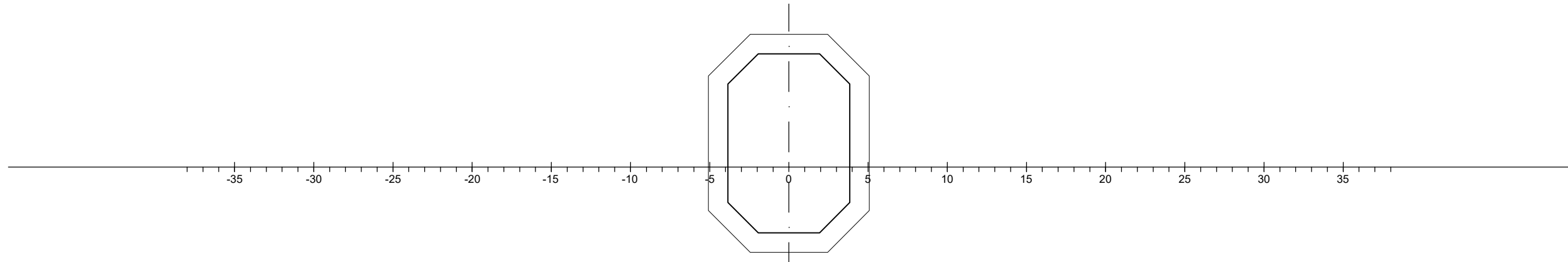

TOP OF WHEELHOUSE
14100 AB.BL.

C

C

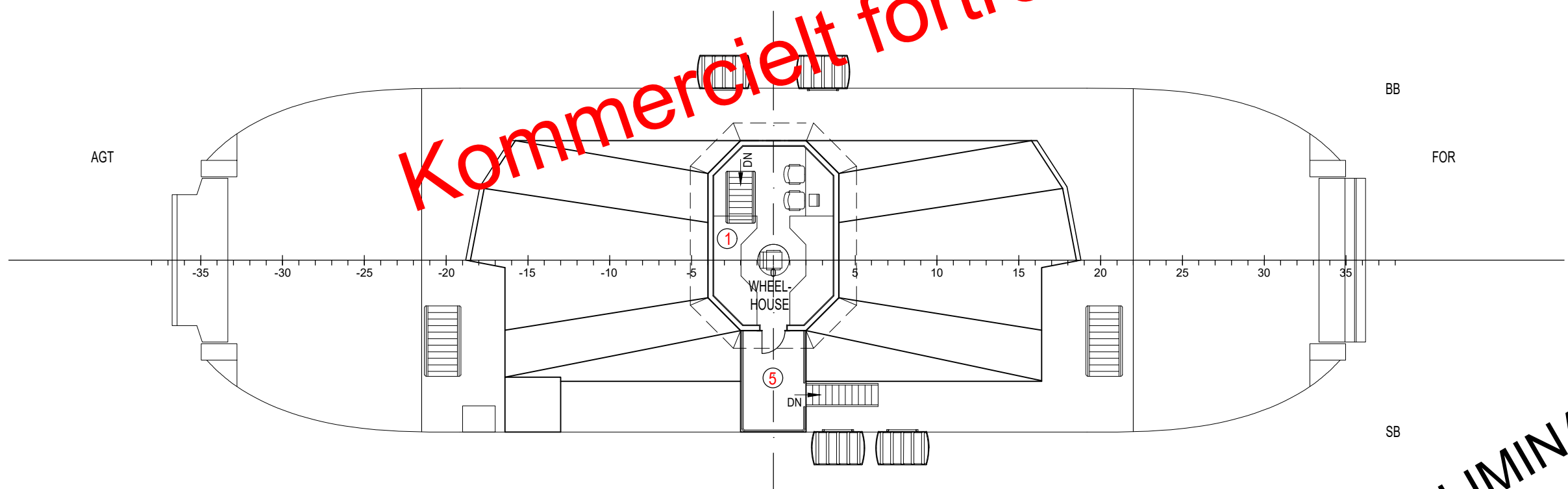

WHEELHOUSE DECK
11400 AB.BL.

B

B

A

Print: 2023-08-29 11:30 A

Kommercielt fortroligt

PRELIMINARY

©2023. The information contained in this document is the property of Odense Maritime Technology A/S and shall be kept secret at all times. The information herein constitutes business secrets of Odense Maritime Technology A/S and is protected by copyright law and international copyright conventions. You may, however, print a number of copies for scrutiny by your employees and submit electronic copies to members of your project team. All copies, irrespective of format, of the information shall, upon Odense Maritime Technology A/S' request be returned or destroyed. Except as stated above, the information may not be shared with others, copied or reproduced in any way or format without the prior written consent of Odense Maritime Technology A/S.



Project: D37-10
 STANDARD FERRY - SVENDBORG
 GENERAL ARRANGEMENT
 CONCEPT DESIGN

Project No.: M994	
Scale: 1:150	Size: A3
Drw.: BOP	Date: 2023-04-28
Drg. No.: 101-000-010	
Sheet 3 of 6	Rev.: F

6 5 4 3 2 1

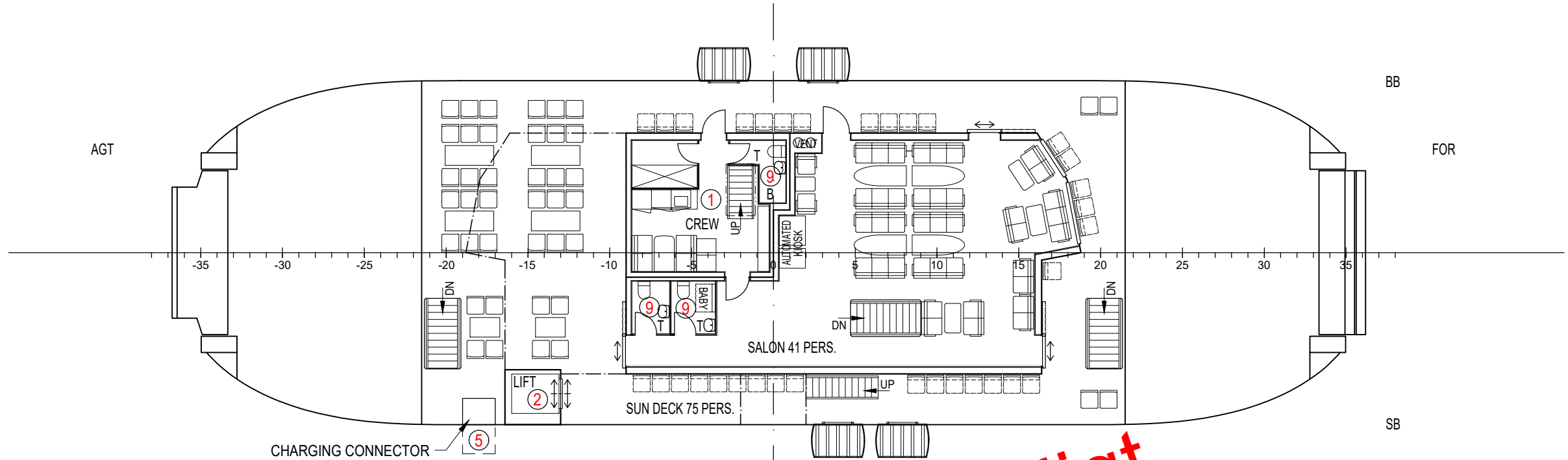

SUN DECK
9000 AB.BL.

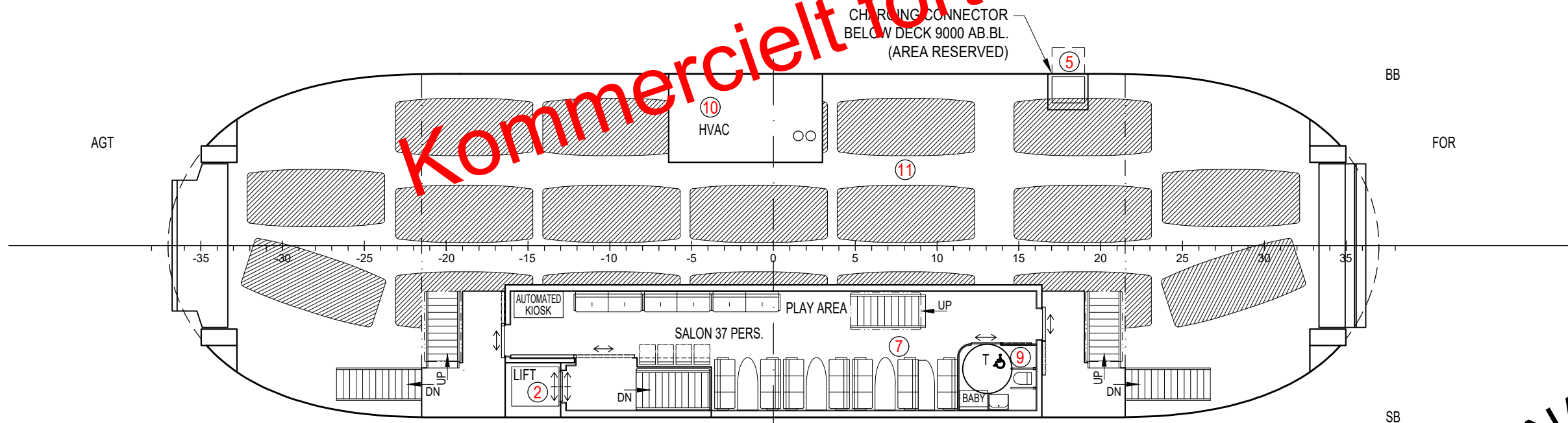

SALON DECK
6450 AB.BL.

Kommercielt fortroligt

PRELIMINARY

©2023. The information contained in this document is the property of Odense Maritime Technology A/S and shall be kept secret at all times. The information herein constitutes business secrets of Odense Maritime Technology A/S and is protected by copyright law and international copyright conventions. You may, however, print a number of copies for scrutiny by your employees and submit electronic copies to members of your project team. All copies, irrespective of format, of the information shall, upon Odense Maritime Technology A/S' request be returned or destroyed. Except as stated above, the information may not be shared with others, copied or reproduced in any way or format without the prior written consent of Odense Maritime Technology A/S.

OMT

Odense Maritime
Technology A/S
www.odensemartime.com

Project: D37-10
STANDARD FERRY - SVENDBORG
GENERAL ARRANGEMENT
CONCEPT DESIGN

Project No.: M994	
Scale: 1:150	Size: A3
Drw.: BOP	Date: 2023-04-28
Drg. No.: 101-000-010	
Sheet 4 of 6	Rev.: F

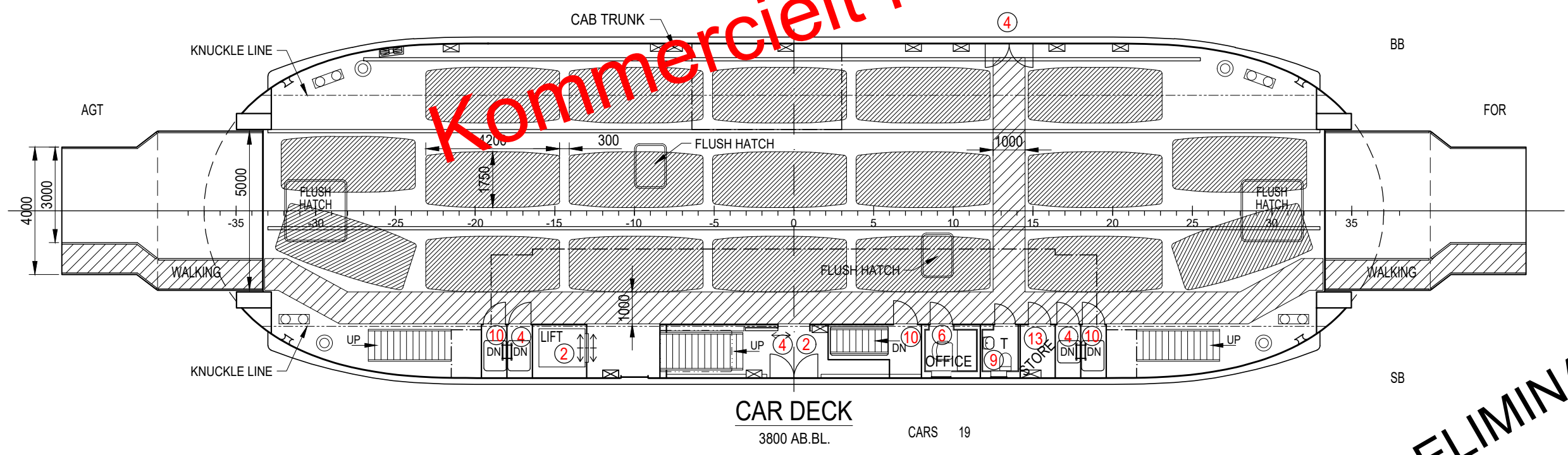
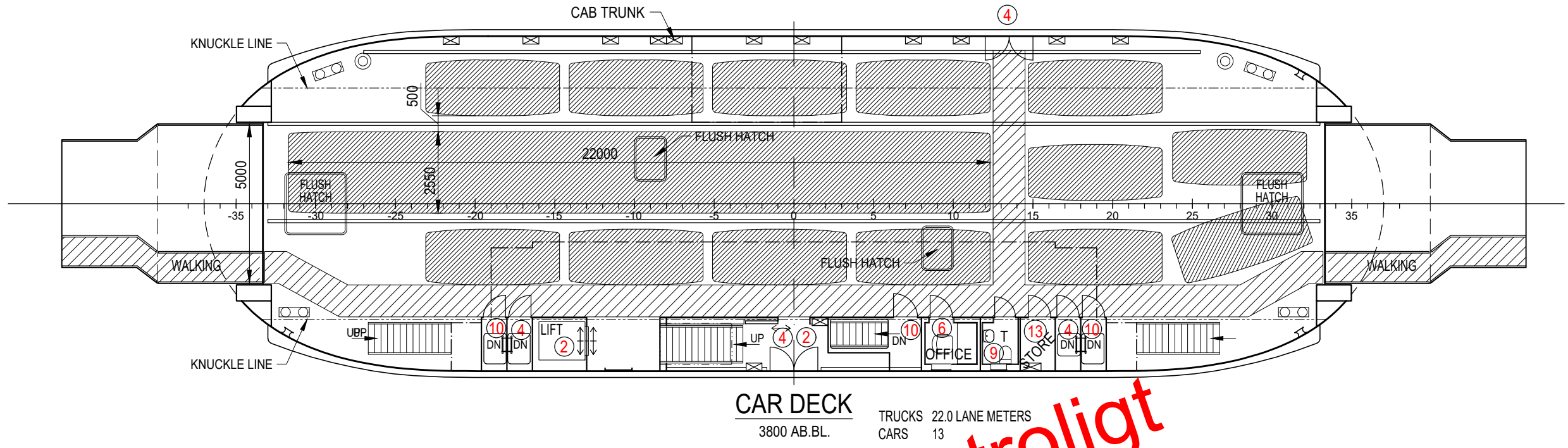

PRELIMINARY

©2023. The information contained in this document is the property of Odense Maritime Technology A/S and shall be kept secret at all times. The information herein constitutes business secrets of Odense Maritime Technology A/S and is protected by copyright law and international copyright conventions. You may, however, print a number of copies for scrutiny by your employees and submit electronic copies to members of your project team. All copies, irrespective of format, of the information shall, upon Odense Maritime Technology A/S' request be returned or destroyed. Except as stated above, the information may not be shared with others, copied or reproduced in any way or format without the prior written consent of Odense Maritime Technology A/S.

OMT
Odense Maritime
Technology A/S
www.odensemartime.com

Project: D37-10
STANDARD FERRY - SVENDBORG
GENERAL ARRANGEMENT
CONCEPT DESIGN

Project No.: M994	
Scale: 1:150	Size: A3
Drw.: BOP	Date: 2023-04-28
Drg. No.: 101-000-010	
Sheet 5 of 6	Rev.: F

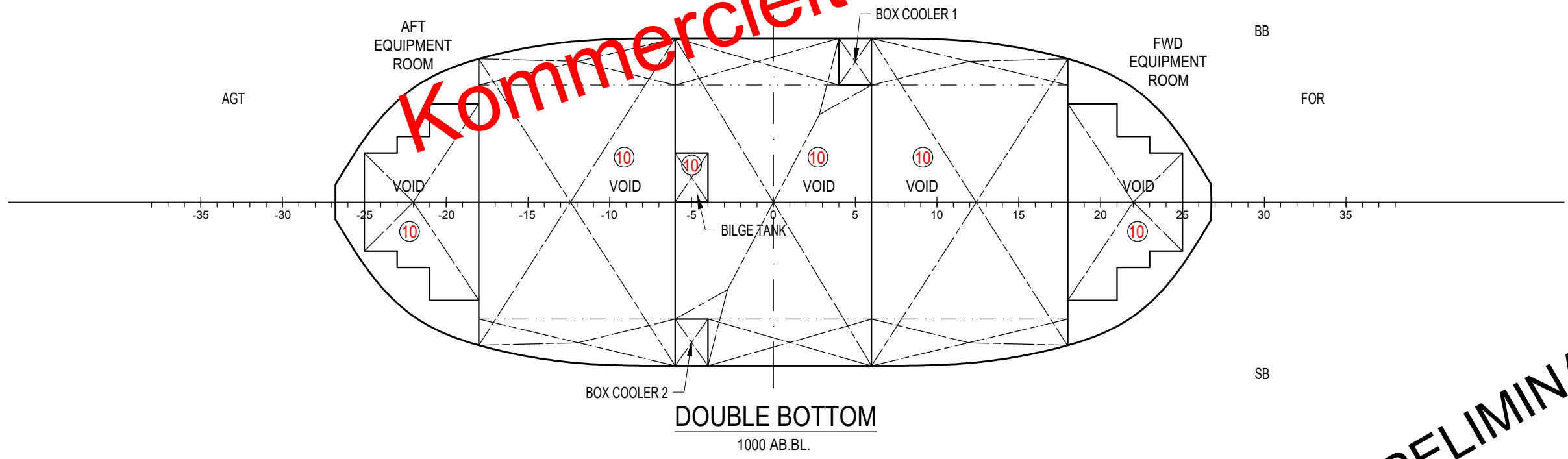
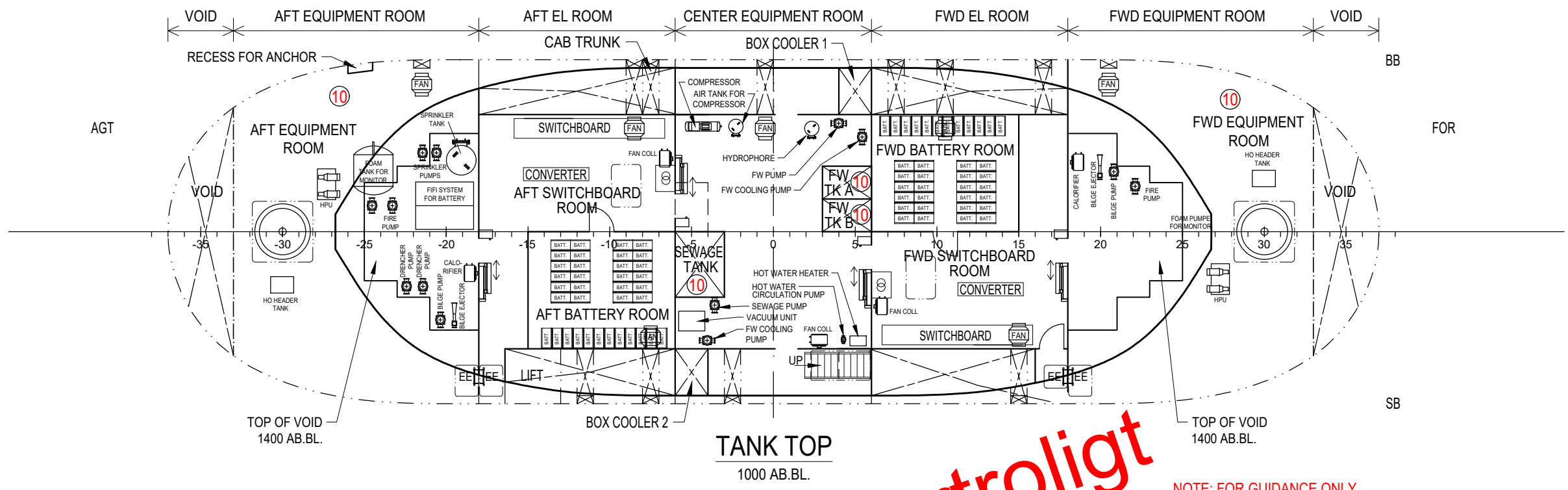

PRELIMINARY

©2023. The information contained in this document is the property of Odense Maritime Technology A/S and shall be kept secret at all times. The information herein constitutes business secrets of Odense Maritime Technology A/S and is protected by copyright law and international copyright conventions. You may, however, print a number of copies for scrutiny by your employees and submit electronic copies to members of your project team. All copies, irrespective of format, of the information shall, upon Odense Maritime Technology A/S' request be returned or destroyed. Except as stated above, the information may not be shared with others, copied or reproduced in any way or format without the prior written consent of Odense Maritime Technology A/S.

OMT
Odense Maritime
Technology A/S
www.odensemartime.com

Project: D37-10
STANDARD FERRY - SVENDBORG
GENERAL ARRANGEMENT
CONCEPT DESIGN

Project No.: M994	
Scale: 1:150	Size: A3
Drw.: BOP	Date: 2023-04-28
Drg. No.: 101-000-010	
Sheet 6 of 6	Rev.: F